

FarmTek

Sport Timing Specialists



Polaris

Multi-Event Timer

Operating
Instructions

FarmTek, Inc.
1000-D Hwy 78 North
Wylie, TX 75098

(972) 429-0947
(800) 755-6529

POLARIS TIMER CONSOLE

Timer Console Power

Batteries

The new *Polaris* timer is powered by four AA alkaline batteries instead of an AC adapter as in the past. The timer runs 50 to 60 hours on a new set of batteries. Always turn the timer off before changing the batteries and always replace all four batteries at the same time – do not mix old and new batteries.

To check the battery level, follow these steps:

- 1) Press SETUP to access setup functions.
- 2) Press NEXT CHOICE until Check Battery is displayed (just one or two presses).
- 3) Press ENTER to show remaining battery life.
- 4) Press SETUP to return to normal operation.

Keep in mind that when the console is first turned on after being off for a while (e.g., overnight), the re-

ported battery level is artificially high for the first half-hour or so of use.

Low Battery Warning

A low battery icon is flashed in the upper right corner of the Status display when about 2 to 4 hours of console battery life are left. Note that the battery icon is also displayed whenever an electric eye in the arena has a low battery. Check the console's battery level as described previously to see if it is the reason the icon is flashing.

Power On/Off

Turn the *Polaris* timer on and off using the slide switch located at the upper right corner of the timer console.

Timer Connections

Connections on the rear of the timer console have changed with the introduction of the new *Polaris* timer. The **Power** jack is gone and in its position is the **Input** jack. The **Input** jack is for connection of optional input devices such as a bar code reader and numeric keypad to be offered in the future. **Do not plug an AC adapter from an older FarmTek timer into the Input jack on the new *Polaris*. It can cause serious damage!**

The **Display** jack is now called the **Output** jack, however, its functions are the same: Output of scoreboard data and output of computer/printer data.

The functions of the **Horn** jack are unchanged from the previous version of the *Polaris* timer: It provides audio output of the horn sound to a PA system and also connects to our stand-alone horn.

WIRELESS ELECTRIC EYES

Operation

Batteries

The electric eyes operate over 70 hours from a 9 volt alkaline battery (*use only alkaline batteries*). The **Power** lamp on the unit glows steadily while the battery is good and flashes when the battery is low.

To help detect an eye with a low battery, the **Polaris** timer in the announcer's booth **flashes a low battery icon** in the upper right corner of its Status Display when any electric eye in use has a low battery.

The electric eyes operate at least two hours after the *first* indication of low battery. **Note:** The two hour period is from the *first time* the low battery light begins flashing. If a unit with a low battery is turned off and then later turned back on, the lamp may glow steadily for some time before it starts flashing again. This does not mean there are two more hours of operation remaining at this point.

Once the **Power** lamp begins flashing, it is simplest to just replace the battery during the next break in your event – don't worry about trying to use the last few hours of the battery.

When storing the electric eyes for an extended period of time, always remove the batteries.

Helpful Hints

Even though the antennas can be unscrewed, doing so can cause problems: **Do Not Remove the Antennas!** Placement of the electric eyes and the timer console in the arena and the announcer's stand can affect performance of the radio link. Note these guidelines:

- 1) Ensure an unobstructed line-of-sight between the antenna on the electric eye and the antenna on the timer console in the announcer's booth. Verify clear line-of-sight from down at the antenna's level – not from your standing eye level.
- 2) Position the timer console at least 2-3 feet from major electronic equipment such as computers, monitors, and the PA system.

Optical Interference from the Sun

When the electric eyes are setup with more than 100 feet between them, a late afternoon sun shining directly into the Photo-Receiver (the electric eye *with* the antenna) can cause problems. A simple remedy is to swap the electric eyes with each other so that the sun shines into the face of the Photo-Transmitter instead (the electric eye *without* the antenna). Or, you can construct a shade for the Photo-Receiver – see a sample sun-shield to print and cut out on the web at: farmtek.net/sunshield.htm.

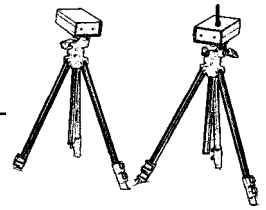

Two Timers At Once

Two complete timers can be used at the same time to provide back-up for each other. However, when two Photo-Transmitters (the infrared light source) are on at the same time, they interfere with each other at the Photo-Receiver. To prevent problems, set up both complete timers, stacking the electric eyes on top of each other. However, *only turn on one of the Photo-Transmitters*. Both Photo-Receivers will "see" the beam, but since the beam is coming from just one Photo-Transmitter, there is no interference.

Note: Older wired electric eyes may not "recognize" the wireless Photo-Transmitter. In this situation, make

sure the one Photo-Transmitter that you turn on is the older, wired Photo-Transmitter – both the wired and wireless Photo-Receivers will operate from the older, wired Photo-Transmitter.

Two Wireless Timers at Once

If the two timers in use are both wireless timers, then in addition to the requirements already mentioned, make sure the two Photo-Receivers (the electric eye with the antenna) operate on *different* channels. The channel number used by the Photo-Receiver is stamped inside the battery compartment.

Electric Eye ID Codes

WIRELESS ELECTRIC EYES (2)

Each wireless electric eye is permanently programmed with an electronic identification code. No two units have the same ID code. The ID code is transmitted along with other information whenever the electric eye beam is broken or restored. For a set of wireless electric eyes to work with a particular timer console, the timer console must “know” the ID code of the electric eye being used.

If you use a different set of electric eyes or a different timer console than usual, you must have the timer

console “learn” the ID code of the electric eyes being used as detailed below.

Note that the Polaris timer supports up to four sets of electric eyes. These are referred to as Eye #1, Eye #2, Eye #3 and Eye #4. The table below shows which eyes are used for each event. *If a new ID code is learned for Eye #1, then all events that use Eye #1 are also affected.* The same logic applies when the ID code for any other eye is updated.

Event	Eye #1	Eye #2	Eye #3	Eye #4
Barrel Racing	Start/Stop			
Roping	Steer (Start)	Header (Breakout)	Heeler (Breakout)	
Bull Riding				
Team Penning	Start (Optional)			
Cutting	Start (Optional)			
Show Jumping	Start/Stop	Start/Stop	Start/Stop	
Lap Timing	Start/Stop			
Sprint/General	Start/Stop	Start/Stop	Split Time	Split Time
Time Stamp	Time Message	Time Message	Time Message	Time Message

Learning a New ID Code

- 1) Set up the electric eyes and the timer console as normal for the event you are performing. (The alignment indicators on the timer console may not update until after the ID codes have been set.)
- 2) On the timer console, press the SETUP button to access the timer Setup options.
- 3) Press NEXT CHOICE until Set Eye#1 ID is displayed. (For some events, like Roping and Show Jumping, you can choose from two or three different eyes – choose the one you need to set.)
- 4) When you are ready to break the electric eye beam, press ENTER. The timer will display Break Eye#1 Beam Now... (or the appropriate message for the eye you selected).
- 5) Walk through the selected electric eye beam. As soon as the beam is broken, the timer momentarily displays the ID code for the eye.

That’s it! For events like Roping or Show Jumping, repeat the procedure for other eyes, if needed.

Note: If the “Break Eye Beam Now...” message remains on the display, the timer did not receive a transmission from the electric eye. Make sure the eyes are on and visually aligned, then walk through the beam again. If the timer still fails to receive an ID code, move the eyes closer to each other and closer to the timer console (try less than 100 feet).

For events which can use more than two sets of eyes, learning the ID code for Eye 3 or 4 enables those eyes. Conversely, to disable an electric eye that is not used, follow steps 2 to 4 for the eye you wish to disable, then abort the programming process by pressing any button on the keypad. This disables the selected electric eye.

WIRELESS HANDSWITCH

Overview of Operation

The wireless handswitch adds flexibility to several events supported by the **Polaris** timer. The wireless handswitch can be used to start and stop the timer for *Bull Riding*, *Team Penning*, *Cutting*, etc. For *Ranch Sorting*, the handswitch is used to mark the split time at which each cow is sorted. For *Team Roping*, the handswitch is carried by the judge in the arena and is set to stop the timer only. For *Show Jumping* and *Power & Speed* events, the handswitch is used to stop and start the timer when a jump is dislodged: Pressing the handswitch while the timer is running sounds two bursts of the horn and stops the timer. Pressing the button again sounds the horn and re-

sumes timing. For *Lap Timing*, the handswitch can be used in place of the electric eyes to allow manual timing of laps.

The *Average Time* event is used for hand timing of Roping, Steer Wrestling, Goat Tying, etc. This event averages the times of two timekeepers and requires at least one wireless handswitch. With a single handswitch, one timekeeper uses the Start/Stop button on the timer console and the other timekeeper uses the wireless handswitch. A second wireless handswitch can be used so that neither timekeeper is tied to the timer console.

Handswitch Operation

The wireless handswitches are designed for operation within about 100 feet of the timer console. The handswitch is similar to the wireless electric eyes and **must be turned on** by pressing the red power button on the front panel. Once powered on, the handswitch is operated by pressing the green button on top of the handswitch with your thumb.

Two Handswitches Used at the Same Time

If the two handswitches are in use at the same time, make sure they operate on *different* channels. The channel number is between 0 and 3 and is stamped on a small yellow sticker inside the battery compartment of the handswitch.

Handswitch ID Code

Each handswitch is permanently programmed with a unique electronic identification code. For a handswitch to work with a particular timer console, the timer console must “know” the ID code of the handswitch being used.

If you use a different handswitch or a different timer console than usual, or if your handswitch is not working with your console, have the timer console “learn” the ID code of the handswitch(es) being by using the `Set HandSwitch ID` option in the Setup menu.

Batteries

The handswitch operates over 70 hours from a 9 volt alkaline battery (*use only alkaline batteries*). The **Power** lamp on the unit glows steadily while the battery is good and flashes when the battery is low. The handswitch will operate at least two hours after the *first* indication of low battery. However, the two hour period is from the *first time* the low battery light begins flashing. If a unit with a low battery is turned off and then later turned back on, the lamp may glow steadily for some time before it starts flashing again. This does not mean there are two more hours of operation remaining at this point.

Once the **Power** lamp begins flashing, it is simplest to just replace the battery during the next break in your event – don’t worry about trying to use the last few hours of the battery.

When storing the handswitch for an extended period of time, always remove the battery.

HORN OPERATION

The wireless *Polaris* timer supports several different horn options:

- Stand-alone horn.
- A horn built into some scoreboard models.
- The “PA Horn” (a direct connection between the timer console and a PA system).

All horns provide the same functionality as described in the instructions for each event. The primary difference is how each horn connects to the timer.

Note: To check horn operation, you can press the HORN button on the timer console at any time to sound the horn.

Mechanical Horns

Stand-Alone Horn

To connect the stand-alone horn, plug the gray cable which exits from the horn into the **Horn** jack on the rear of the timer console. Plug the black power cord from the horn into a standard 120 volt outlet. *Do not hang or mount the horn by the wires which exit from the horn.* In a wet environment, orient the horn so that the horn’s cables exit downwards.

Scoreboard Horn

The scoreboards which use light bulbs have a horn built into the scoreboard. Whenever the scoreboard is connected to the timer console for normal operation (by connecting the scoreboard’s data cable to the **Output** jack on the timer console), the horn in the scoreboard is also connected – no additional connection to the scoreboard is required to operate the horn.

PA Horn

Connection

The wireless *Polaris* console provides for a direct connection between the timer console and a public address system (PA system). The timer console contains a digitized recording of our loud, stand-alone horn. The PA system performs as if a microphone is in front of a stand-alone horn – except there is no horn and there is no microphone!

To use the PA Horn, connect the “Timer to PA Cable” provided with the timer (10 foot cable with a stereo phone plug on one end and an RCA phono plug on the other end) from the **Horn** jack on the timer console to a *line* input jack on your PA system. (Line input jacks on a PA system are typically labeled with names like “AUX”, “CD Input”, “Tape In”, “Mix In”, etc.)

If a spare line input is not available, or you cannot obtain the desired volume level, a cable to connect the timer to a *microphone* input on the PA is also available. Contact FarmTek for more information.

Disabling the Scoreboard Horn

If you are using one of the two larger scoreboards which has a built-in horn, and you do not want the horn in the scoreboard to sound, follow these steps to disable the horn in the scoreboard:

- a) Press SETUP to access setup functions.
- b) Press NEXT CHOICE until Disable SB Horn is displayed.
- c) Press ENTER to disable the scoreboard horn.

Note: You can re-enable the scoreboard horn when needed by picking Enable SB Horn in step (b).

Different Horn Tones

In addition to the standard bull-horn sound, other horn tones can be selected:

- a) Press SETUP to access setup functions.
- b) Press NEXT CHOICE until Set Horn Sound is displayed, then press ENTER.
- c) Press NEXT CHOICE to scroll through the available horn tones. Press ENTER when the desired tone is displayed.

Overview

QUICK-MOUNT

The *Quick Mount* is a quick and flexible way to mount the Wireless Electric Eyes to virtually any fence pipe, cattle panel, etc. It's great for temporary or permanent installation of electric eyes for roping.

The combination of a ball head, pivoting support arms, and a rotating base allows numerous positioning adjustments as illustrated below.

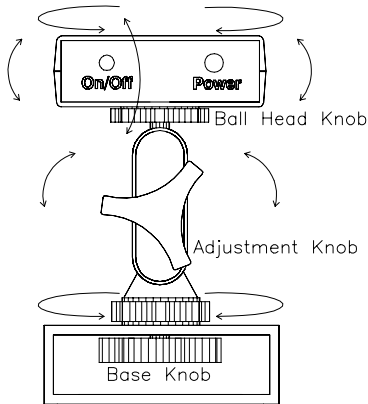

The Quick Mount attaches to fences and posts using plastic tie-wraps. Leave the mount attached for just the night, or leave it attached for months! Additional tie-wraps are available at most hardware and auto-parts stores.

Loosening the *Adjustment Knob* allows movement of the ball head and pivoting of the holding arms. Loosening the knob about 1/2 turn frees the ball head to rotate and swivel. Loosening the knob slightly more allows the arms to pivot.

Loosening the *Base Knob* on the Quick Mount allows rotation of the Quick Mount on its base. This rotation can be used to orient the holding arms so they pivot in the direction you require.

Note: Keeping the eye “flat” as illustrated is only required when mounting the eye *with* the antenna. The electric eye *without* the antenna can be mounted in any orientation required.

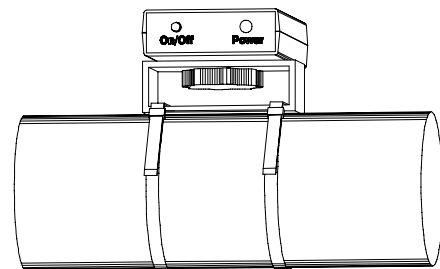
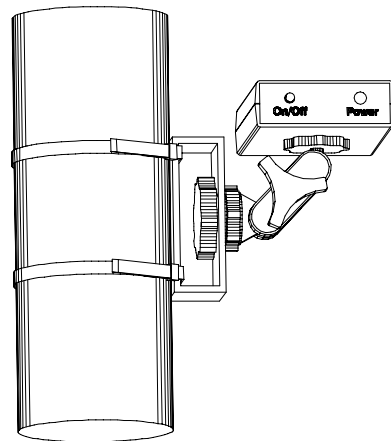
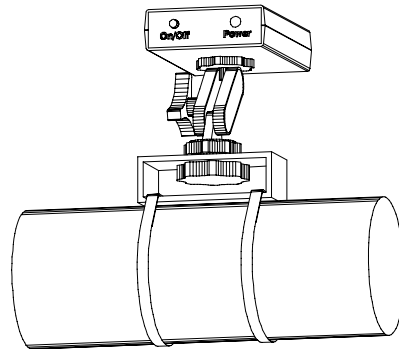

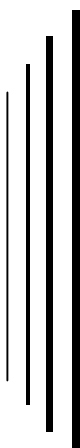

Event Instructions

Preparation For Use

BARREL RACING (1)

- 1) Attach each electric eye to a tripod. Place the eyes on opposite sides of the arena to form a start/stop line between them. *Extend tripod legs fully* to ensure the electric eyes are high enough to be broken by the horse's body (not its legs).
- 2) Turn the electric eyes ON. The power indicator lamp on each unit should glow steadily. If the indicator is blinking, the battery is low and should be replaced.
- 3) Align the electric eyes. The electric eye on the opposite side of the arena should be directly in-line when sighting down either line on top of the electric eye (left to right alignment), and when sighting down the crack on the side of the electric eye (up and down alignment).
- 4) Turn on the timer console in the announcer's booth. The power switch is located at the upper right corner of the timer.
- 5) The current event type (Barrel Racing, Roping, etc.) is shown on the Status display on the timer console. *If BARREL RACING is not displayed, select the Barrel Racing event as follows:*
 - a) Press SETUP to access Setup functions.
 - b) Press ENTER to select a new event.
 - c) Press ENTER to select Barrel Racing.
- 6) Walk through the electric eye beam to force the eyes to send a message to the timer console. This makes the timer console update its electric eye alignment indicator (see below).

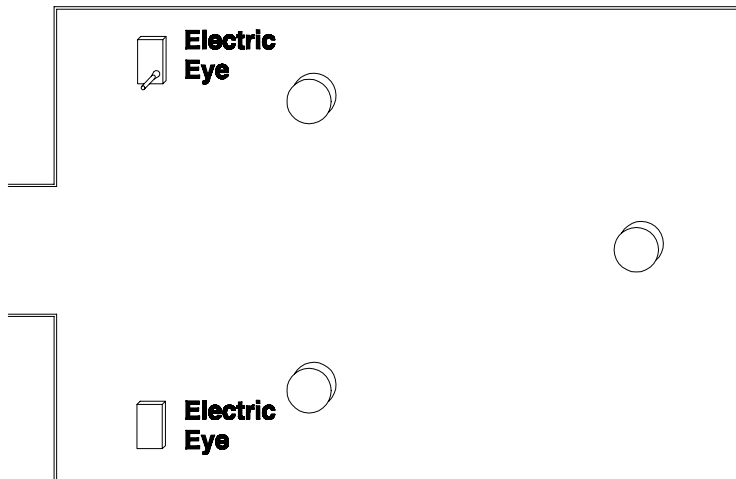

Typical Barrel Racing Layout

Checking Eye Alignment

The **bottom right corner** of the Status display shows the alignment status of the electric eyes. When the eyes are aligned, the eye number is displayed (“#1”). If not aligned, or if the beam is broken, “x” is shown.

Alignment	Display Shows
Eyes aligned	Eye #1
Not aligned (or beam broken)	Eye #x

Important! When setting up the electric eyes, always take time to align the eyes as outlined above – *even if the timer indicates the eyes are aligned*. This ensures a strong alignment instead of a possibly marginal alignment.

Timer Operation

BARREL RACING (2)

When the rider enters the arena and breaks the beam, the timer automatically begins timing from zero. The timer *does not* need to be reset to zero before the rider starts! Once broken, the beam is ignored for about two seconds to allow dust to settle.

As the rider completes the run and breaks the beam again, the timer stops and shows the final time. The timer is now ready for the next rider! (As when starting the timer, the beam is ignored for about two seconds after stopping to allow dust to settle.)

Useful Features

Manual Start/Stop

The START/STOP button starts and stops the timer just as if the electric eye beam had been broken.

Accidental Beam Break

If the timer accidentally stops during the middle of a run, *the rider can still be accurately timed*. Pressing the RESTART button resumes timing as if the timer had never been stopped. As long as RESTART is pressed before the rider finishes, the time is not lost.

Locking Out The Electric Eyes

For events which require the rider to pass through the beam multiple times during a run, you can manually or automatically disable the eyes during the run, then re-enable the eyes prior to the final pass.

To manually disable the electric eyes, press the EYES OFF button. "OFF" is flashed over the electric eye alignment display while the eyes are off. To re-enable the electric eyes, press the EYES ON button.

To automatically ignore one or more passes in the middle of a run, choose "Eye Off Setting" in the setup menu, key in the number of passes to ignore and then press ENTER. Setting the number of passes back to zero, or turning the timer off and back on, restores normal operation.

Previous Time Recall

Use the PREV and NEXT keys to scan back and forth through previous times. The previous time display is removed after about ten seconds, or by pressing any other key. You may view a previous time even while the timer is running.

Skipping a Rider / No Time

If using the optional printer, pressing the NO TIME button prints "-- No Time --" on the printer. This ensures a line is present on the printer for each contestant registered to ride.

Penalties

Entering a Penalty

With the timer stopped, press the SCORE/PENALTY button. Then, key in the penalty, followed by the ENTER button. Pressing the decimal point button moves the input cursor to the right of the decimal. However, zeros to the right of the decimal do not need to be entered.

After the penalty is entered, the Time display is updated to include the penalty. The Status display shows the original time and the penalty value. If a scoreboard is connected, it shows the time including

penalty. If a printer is connected, an additional line is printed showing the penalty and time with penalty.

Correcting Mistakes

To correct a mistake while entering a penalty, press *and hold down* the CLEAR TIME button until the timer beeps and the penalty value is cleared to zero.

If ENTER has already been pressed, simply start the penalty entry process over – the new entry replaces the previous penalty.

Preparation For Use

ROPING (1)

- 1) Decide where and how each electric eye pair will be mounted. A typical set-up is shown below (the heeler eye is optional). Choose eye locations that are not likely to be hit by riders or the steer.
- 2) Mount each electric eye on a *Quick-Mount* or a tripod. It is best to orient the eye which has the antenna such that the antenna is pointed straight up. The eye without the antenna can be oriented as convenient. Note the flexible positioning provided by the *Quick-Mount* allows you to “recess” the eye out of the way slightly.
- 3) Turn the electric eyes ON. The power indicator lamp on each unit should glow steadily. If the indicator is blinking, the battery is low and should be replaced.
- 4) Align the electric eyes. The opposite electric eye should be directly in-line when sighting down either line on top of the eye (left to right alignment), and when sighting down the crack on the side of the eye (up and down alignment).
- 5) With the timer console OFF, connect the timer console to whichever horn you are using (see the *Horn Operation* instruction page.)
- 6) Turn on the timer console in the announcer's booth. The power switch is located at the upper right corner of the timer.
- 7) The current event type (Barrel Racing, Roping, etc.) is displayed on the timer. *If ROPING is not displayed, select the Roping event as follows:*
 - a) Press SETUP to access Setup options.
 - b) Press ENTER to pick a new event.
 - c) Press NEXT CHOICE until Roping is displayed.
 - d) Press ENTER to select the Roping Event.
- 8) Walk through each eye beam to force the eyes to send a message to the timer console. This makes the timer console update its electric eye alignment indicator (see the next page).

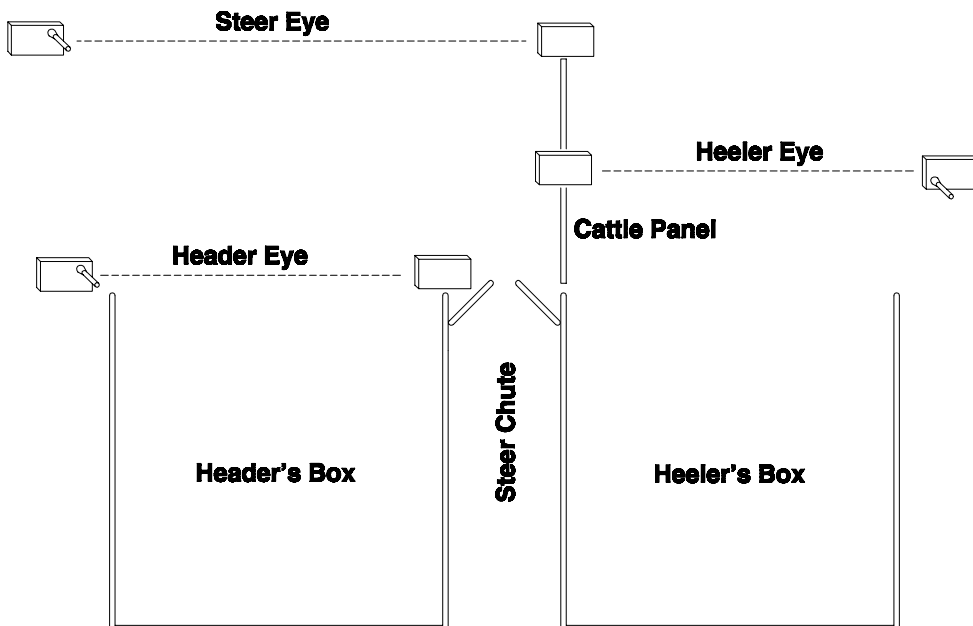

Checking Eye Alignment

ROPING (2)

The bottom right corner of the Status display shows the alignment status of each electric eye. When an electric eye is aligned, its eye number is displayed. If not aligned, an “x” is displayed. Eye #1 is the steer eye, #2 is the header eye, #3 is the heeler.

Note: After the timer is first turned on, or the “Roping” event has just been selected, the eyes all show “x” until each beam is broken for the first time.

Alignment Indicator Example

Alignment	Display Shows
All eyes aligned.	Eye #1 <u> </u> <u> </u> <u> </u>
Header eye not aligned (or beam is broken)	Eye #1 <u> </u> <u> </u> <u> </u>

Timer Operation

- 1) When the steer breaks its beam, the timer automatically begins timing from zero. Once started, further interruptions of the electric eyes are ignored while the timer is running.
- 2) When the judge drops the flag, press the START/STOP button to stop the timer.
- 3) The timer is now ready for the next team. No reset is required!

Broken Barrier

If the header breaks the barrier, the horn sounds briefly and the message “Header” is displayed. If the heeler breaks out, the horn sounds two short bursts and “Heeler” is displayed. The breakout message remains on the display until it is automatically removed when the timer starts for the next rider.

Clean Start

If the rider does not break the barrier, the message “Clean Start” is displayed momentarily when the steer starts the timer.

By the way...

The timer records a broken barrier only if the timer is started (steer released). Breaking the rider's beam without the release of a steer (front loading the box, crossed by workers, etc.) *does not* cause the timer to display or save the fault.

The timer can be set to sound the horn when the timer records the fault as detailed above, *or* the horn can be sounded *any time* the rider's beam is broken. See the *Roping (4)* page for details.

Breakout Timer

The breakout time is the amount of time the header is behind the steer (clean start) or ahead of the steer (breakout). When the *breakout timer* feature is enabled, the breakout time is displayed on the timer's Status display and on the optional scoreboard. Clean starts are displayed as positive values. Breakouts are displayed as negative values.

Enabling the Breakout Timer

To turn display of the breakout timer on or off, follow these steps:

- 1) Press SETUP to access setup functions.
- 2) Press NEXT CHOICE until Brkout Time ON or Brkout Time OFF is displayed.
- 3) Press ENTER to turn the breakout timer on or off as selected in step 2.
- 3) The Set Hold Time option is displayed. Press ENTER.
- 4) Press NEXT CHOICE as needed to scroll through the hold time options. When the desired hold time is displayed, press ENTER.

- 3) Press ENTER to turn the breakout timer on or off as selected in step 2.

Changing the Scoreboard Hold Time

The amount of time the breakout time is held on the scoreboard can be changed as follows:

- 1) Press SETUP to access setup functions.
- 2) Press NEXT CHOICE until Scorebd Options is displayed, then press ENTER.
- 3) The Set Hold Time option is displayed. Press ENTER.
- 4) Press NEXT CHOICE as needed to scroll through the hold time options. When the desired hold time is displayed, press ENTER.

Accidental Timer Stop

If the timer is accidentally stopped during the middle of a run, *the rider can still be accurately timed* by pressing the RESTART button. (The timer continues timing even when stopped.) As long as RESTART is pressed before the ride is completed, no time is lost.

Previous Time Recall

Use the PREV and NEXT keys to scan back and forth through previous times. Broken barriers, “No Times”, and penalties (if entered) are all saved.

The previous time display is removed after about ten seconds, or by pressing any other key. You may view a previous time even while the timer is running.

No Time

To record a “No Time,” press the NO TIME button after stopping the timer. The message “No Time” is displayed, and if using the optional printer, a “No Time” message is printed. The “No Time” is also displayed whenever the rider's time is recalled later.

Penalties

Entering a Penalty

To enter a penalty, press the SCORE/PENALTY button. To accept the default penalty that is shown, press ENTER, otherwise, key in a new penalty, followed by the ENTER button. (Note: pressing the decimal point button moves the input cursor to the right of the decimal. However, *zeros to the right of the decimal do not need to be entered*).

After the penalty is entered, the Time display is updated to include the penalty. The Status display shows the original time and the penalty value. If a scoreboard is connected, it shows the time including

penalty. If a printer is connected, an additional line is printed showing the penalty and time with penalty.

Correcting Mistakes

To correct a mistake while entering a penalty, press *and hold down* the CLEAR TIME button until the timer beeps and the penalty value is cleared to zero (about one second).

If ENTER has already been pressed, simply start the penalty entry process over – the new entry replaces the previous penalty.

Practice Mode

In the **Practice Mode** of the Roping event, the timer stops itself after about three seconds to let you practice against the barrier without needing someone to stop the timer. To select the roping practice mode:

- 1) Press SETUP to access Setup options.
- 2) Press NEXT CHOICE until Practice Mode is displayed and then press ENTER.

The timer remains in practice mode until the timer is turned off or you re-select the Roping event as detailed on the first page.

Breakout Timer for Practice

The **Breakout Timer** of the *Sprint/General* event may be more suitable for practice than the “main” breakout timer described previously. The breakout timer of the *Sprint/General* event leaves the breakout time on the main timer display and on the scoreboard so you can more easily view the breakout time after each run. See page 3 of the *Sprint/General* event in this manual for details.

Each wireless electric eye is assigned a permanent and unique electronic ID code. To operate properly, the Polaris timer must “know” the ID code of each electric eye in use.

Prior to shipment, your Polaris timer was “taught” the ID code for each electric eye you purchased. For your convenience, the electric eyes were labeled with their

corresponding use (steer, header, heeler) as set from the factory.

If the stickers come off the electric eyes, or you need to swap eye locations or use a backup electric eye, you must force the Polaris timer to re-learn the ID code of the affected eye (steer, header, or heeler). Refer to the *Wireless Electric Eyes* page for detailed instructions on programming an eye into the timer.

Customizing Your Timer

The Polaris timer has many features that can be customized to meet the particular needs of you and your arena. These items are changed using a “menu” of different setup options. **Changing settings is easy:**

- 1) With the timer stopped, press the SETUP button to access the setup options.
- 2) If the desired option is displayed, do what is instructed on the display (usually, just pressing the ENTER button). Otherwise, press NEXT CHOICE to show the next available option.

Note the following:

- You can exit Setup without making a change by pressing the SETUP key, or by selecting the Exit Setup option when it is displayed.
- To help you identify the settings currently in use, an asterisk (*) is displayed next to an item when it is the present setting.
- Changes you make are permanently saved until changed again using the Setup menu.

Common Setup Options (change these as outlined above)

Following are a few Setup options that you may want to change. Use the procedure described above to change these items. In addition to the items listed here, there are other options that can be changed to customize your timer. *If the timer is not doing exactly what you need, chances are, it can – call us for assistance!*

Front Loading Rider Boxes

If your arena requires the rider to pass through the barrier beam as he rides into the box – and this causes the horn to sound each time – you can change when the horn is sounded by choosing between the following two options:

- 1) Horn with Rider – Factory default. The horn sounds any time the rider's beam is broken and the timer is not running. For example, the horn will sound as a rider front loads the box.
- 2) Horn with Steer – The horn sounds only if the rider breaks his beam and a steer is released. The steer must start the timer within two seconds after the rider's beam is broken.

Yet another way of controlling when the horn sounds is to change the Auto Eye Off setting:

- 1) Auto Eye Off – Automatically disables all electric eyes after each run. When the next rider is ready, turn the eyes back on by pressing the EYES ON button.
- 2) No Auto Eye Off – Factory default. The electric eyes are always enabled. No button presses are required between riders.

Time Expired Horn

To speed up the roping and reduce cattle fatigue, you can set a horn to sound at a specified time limit with the Set Final Horn option. When prompted to key in a new time, key-in the desired time limit followed by the ENTER key, or simply press ENTER to keep the value already displayed. When a limit other than zero is specified, the timer will automatically stop and sound the horn when the time limit is reached.

Overview of Operation

AVERAGE TIME

The *Average Time* event is used to manually time events with two timekeepers. The two times are averaged and displayed on the **Polaris** numeric display and on the arena scoreboard. While there is only one *physical* timer (the **Polaris** timer console), the timer console internally maintains two independent times referred to as *Timer A* and *Timer B*.

Timer A

Timer A is controlled by the START/STOP button on the timer console or, by handswitch #2. *Timer A* is displayed on the left side of the **Polaris** status display. When *Timer A* is running, it also displayed on the **Polaris** numeric display and on the arena scoreboard.

Timer B

Timer B is controlled by handswitch #1. *Timer B* is displayed only on the right side of the **Polaris** status display.

Averaging of Times

When both *Timer A* and *Timer B* have stopped, the **Polaris** attempts to compute an average time. The average time is displayed on the **Polaris** numeric display and on the arena scoreboard. If a penalty is entered, the penalty is added to the averaged time.

If an average cannot be computed, “Error” is displayed on the **Polaris** numeric display and the value of *Timer A* is shown on the arena scoreboard. “Error” is displayed for the following reasons:

- 1) *Timer A* and *Timer B* differ by more than 0.4 seconds.
- 2) *Timer A* and *Timer B* were started more than 0.8 seconds apart from each other.

Note: The time variations which define an error condition can be changed. Contact FarmTek for assistance.

Preparation and Operation

Preparation

The current event type is shown on the status display on the timer console. If *Average Time* is not displayed, select the *Average Time* event as follows:

- 1) Press SETUP to access setup functions.
- 2) Press ENTER to select a new event.
- 3) Press NEXT CHOICE until *Average Time* is displayed.
- 4) Press ENTER to select the *Average Time* event.

The wireless handswitches must be turned on in order to operate. Press the red on/off button to turn the handswitch on. The “Power” indicator lamp

should glow steadily. If flashing, the battery in the handswitch is low and should be replaced.

Operation

- 1) Before each run, make sure both *Timer A* and *Timer B* are stopped. They do not need to be cleared to zero – just stopped.
- 2) Press the green button on the handswitch and/or the START/STOP button on the timer console to start and stop the corresponding timer. See the “Overview” above for details about where times are displayed and how average times are computed.

Preparation For Use

BULL RIDING

- 1) Connect the timer to whichever horn you are using (see "Horn Operation" page).
- 2) Turn on the timer console. The power switch is located at the upper right corner of the timer.
- 3) The current event type (Barrel Racing, Bull Riding, etc.) is shown on the Status display on the timer console.

If BULL RIDE is not displayed, select Bull Riding as follows:

- a) Press SETUP to access setup functions.
- b) Press ENTER to select a new event.
- c) Press NEXT CHOICE until Bull Riding is displayed.
- d) Press ENTER to select Bull Riding.

Setting The Ride Time

Quick Select of a Standard Ride Time

The time at which the horn sounds is shown on the first line of the Status Display. The timer provides easy access to typical ride times (3 through 8 seconds). To select a different ride time:

- 1) Press SETUP to access setup features.
- 2) Press NEXT CHOICE until the desired ride time is displayed.
- 3) Press ENTER to activate the ride time shown.

Entering a Custom Ride Time

To enter a time other than 3 through 8 seconds, follow these steps:

- 1) Press SETUP to access setup features.
- 2) Press NEXT CHOICE until Set Horn Time is displayed.
- 3) Press ENTER to display the current horn setting.
- 4) To keep the same time, press ENTER, or, key in a new time followed by the ENTER key.

Timer Operation

- 1) When the bull is released, start the timer by pressing the START/STOP button. The timer automatically starts at zero – no reset is required.
- 2) When time expires, the horn sounds and the timer automatically stops.
- 3) To enter a score, Press the SCORE/PENALTY button. Then, key in the score, followed by the ENTER key. Pressing the decimal point button

moves the input cursor to the right of the decimal. However, zeros to the right of the decimal *do not* need to be entered. Mistake? Press *and hold down* the CLEAR TIME button until the score value is zeroed.

After a score is entered, it is shown on the main time display, on the scoreboard, and on the printer (if connected). The score remains on the display and scoreboard until time starts for the next rider.

Useful Features

Previous Time/Score Recall

Use the PREV and NEXT keys to scan back and forth through previous times and scores. The previous time display is removed after about ten seconds, or by pressing any other key. You may view a previous score even while the timer is running.

Skipping a Rider / No Score

The timer will print "-- No Score --" on the optional printer whenever the NO TIME button is pressed or a

score has not been entered and the timer starts for the next rider. This ensures a line is present on the printer for each contestant registered to run.

Accidental Timer Stop

If the timer is accidentally stopped during a run, *the rider can still be accurately timed* by pressing the RESTART button. As long as RESTART is pressed before time expires, timing is resumed without any loss of time.

Preparation For Use

SHOW JUMPING (1)

- 1) Attach each electric eye to a tripod. Place Transmitter/Receiver pairs facing each other to form start/stop lines between the eyes. *Extend tripod legs fully* to ensure the eyes are high enough to be broken by the horse's body (not its legs).
- 2) Turn the electric eyes ON. The power indicator lamp on each unit should glow steadily. If the indicator is blinking, the battery is low and should be replaced.
- 3) Align the electric eyes. The opposing electric eye should be directly in-line when sighting down either line on top of the electric eye (left to right alignment), and when sighting down the crack on the side of the eye (up and down alignment).
- 4) Turn on the timer console in the announcer's booth. The power switch is located at the upper right corner of the timer.
- 5) Walk through each electric eye beam to force the eyes to send a message to the timer console. This makes the timer console update its electric eye alignment indicator (see the next page).

Setting Course Times, Electric Eye Usage

The Polaris timer is easily switched between "First Round" and "Jump-Off Round" (see the *Timer Operation* Section). This capability allows the following:

- Separate course times are maintained for First and Jump-Off rounds. The timer automatically stops and then sounds the horn at twice the course time.
- Computation of time faults can be different for First Round versus Jump-Off Round.
- The way the electric eyes are used to start and stop the timer can be set differently for the First Round and Jump-Off Round. When the timer is switched between rounds, the eye configuration is automatically changed.

The example below shows sample course times and eye usage for First and Jump-Off Rounds:

	First Round	Jump-Off Round
Course Time	72 sec.	68 sec.
Eye Usage	Eye #1 starts Eye #2 stops	Eye #1 starts and stops

- You can press SETUP at any time to exit Setup and return to timing mode.
- These parameters can be updated individually and in any order desired.
- All changes are automatically stored in the timer until changed again in the future.

To Set Course Times and Electric Eye Usage:

- 1) Press SETUP to access timer setup features.
- 2) Press NEXT CHOICE until the 1st Round Time option is displayed and then press ENTER.
- 3) To accept the course time shown, press ENTER, or, key in a new time followed by the ENTER key. (To fix a mistake, press *and hold down* the CLEAR TIME key until the time is cleared).
- 4) After entering the First Round time, the option for entering the Jump-Off Time is displayed. Press ENTER to input the Jump-Off time.
- 5) After entering the Jump-Off time, the option for selecting which eyes are used for the First Round is shown (1st Round Eyes). Press ENTER, then use the NEXT CHOICE key to scroll through the possible eye combinations ("*" is displayed next to the current setting). Press ENTER when the desired eye combination is shown.
- 6) Repeat Step 5 for Jump-Off Round electric eyes.
- 7) Press the SETUP button to exit Setup.

- To disable the display and printing of time faults for a class, enter a course time of zero.
- See the *Show Jumping (3)* and *(4)* page for more setup options.

Checking Eye Alignment

SHOW JUMPING (2)

The bottom right corner of the Status Display shows the alignment status of each electric eye. When an electric eye is aligned, its eye number is displayed. If not aligned, an “x” is displayed.

Alignment	Display Shows
Eyes aligned	Eye #1 \cong
Eye #2 not aligned (or beam broken)	Eye #1 \times

Important! When setting up the electric eyes, always take time to align the eyes as outlined above – *even if the timer indicates the eyes are aligned*. This ensures a strong alignment instead of a possibly marginal alignment.

Timer Operation

- 1) Verify the proper round is shown on the display (FIRST ROUND or JUMP-OFF ROUND).
To change rounds: Press the SETUP key, then press ENTER to accept the new round type.
- 2) Sound the horn and start the rider-start count down by pressing the COUNT DOWN button. If a count down start timer is not needed, sound the horn by pressing the HORN button. Once started, the count down can be paused / resumed with successive presses of the COUNT DOWN button. Press CLEAR TIME to start a new count down.
- 3) Make sure the electric eyes are enabled by pressing the EYES ON button before the rider is ready to cross the start line. When the rider breaks the beam, the timer begins timing from zero and the eyes are automatically turned back off.
- 4) As the rider comes to the end of the course, press the EYES ON button to re-enable the electric eyes. When the beam is crossed, the timer stops and the eyes are automatically turned back off. If the rider's time exceeds the time allowed, time faults are shown on the Status Display. At twice the course time, the timer automatically stops and sounds the horn.
- 5) If the rider is eligible for the Jump-Off, press SETUP and then ENTER to switch rounds.
- 6) Repeat steps 2 through 4 for the Jump-Off Round.

Useful Features

Manual Start/Stop

The timer can be manually started and stopped by pressing the START/STOP button.

Dislodged Jump

If a rider dislodges a jump, sound the horn by pressing the HORN button and stop the clock by pressing the START/STOP button. Press RESTART (**not the START/STOP key**) to resume timing. A wireless handswitch is available as an option to automatically sound the horn and stop the timer, or sound the horn and resume timing.

Adding a Time Penalty (not jumping faults)

With the timer stopped, press the SCORE/PENALTY button, then key in a penalty followed by the ENTER button. The time penalty is added to the rider's time.

Accidental Beam Break

If an electric eye accidentally stops the timer, the rider can still be accurately timed. Pressing the RESTART button resumes timing as if the timer had never been stopped. (**Note:** If the timer is manually stopped using the START/STOP button, RESTART resumes timing from the time shown on the display)

Previous Time Recall

Use the PREV and NEXT keys to scan back and forth through previous times, time faults and the associated round (First Round or Jump-Off). If a course time is changed, then the saved time faults are updated to reflect the new course time.

Several timer options can be changed to support rule variations that may affect your event:

- Time allowed for a rider to start the run.
Default: 45 seconds
- Display format of the starting countdown timer (fractional seconds, whole seconds, etc.),
- What happens when the starting timer expires (sound a horn or start timing).
Default: Start timing
- Faults per second (or other unit of time) for First Round and Jump-Off.
1st Round US: 1 fault/second
1st Round FEI: 1 fault/4 seconds
Jump Off: 1 fault/second

Easy Set-Up

To set all options for U.S. or FEI rules at one time as shown to the left, follow these steps:

- 1) Press SETUP to access timer setup features.
- 2) Press NEXT CHOICE until Rule Options is displayed, then press ENTER.
- 3) U.S. Rules is displayed first. Press ENTER to select U.S. rules, or press NEXT CHOICE to display FEI Rules and press ENTER.
- 4) After ENTER is pressed, the timer momentarily displays Done!, then the chosen rule set is shown again. Press SETUP to exit.

Changing Individual Rule Options

Time Allowed for the Rider to Start

To set the time allowed for the rider to start:

- 1) Press SETUP to access timer setup features.
- 2) Press NEXT CHOICE until Rule Options is displayed, then press ENTER.
- 3) Press NEXT CHOICE until Start Timeout is displayed, then press ENTER.
- 4) The current starting timeout is displayed. To keep the same timeout, just press ENTER, or, key-in a new starting timeout followed by ENTER.
- 5) After ENTER is pressed, the timer momentarily displays Done!, then the Start Timeout menu option is shown again. Press NEXT CHOICE to change other rule options, or press SETUP to exit.

Timer Action upon Starting Timer Expiration

When the rider's starting time expires, the timer can either sound the horn to signal the rider off course, or the timer can start running:

- 1) Press SETUP to access timer setup features.
- 2) Press NEXT CHOICE until Rule Options is displayed, then press ENTER.
- 3) Press NEXT CHOICE until Horn w/Timeout or Start w/Timeout is displayed (your choice), then press ENTER.

- 4) After ENTER is pressed, the timer momentarily displays Done!, then the menu option you selected is shown again. Press NEXT CHOICE to change other rule options, or press SETUP to exit.

Display Format of the Starting Timer

The starting countdown timer can be displayed in any of several time formats. Changing the countdown time format does not affect the time format of normal timing functions. To change the countdown time format, follow these steps:

- 1) Press SETUP to access timer setup features.
- 2) Press NEXT CHOICE until Rule Options is displayed, then press ENTER.
- 3) Press NEXT CHOICE until Timeout Format is displayed, then press ENTER.
- 4) Press NEXT CHOICE to scroll through the different time formats available. When the desired time format is displayed, press ENTER.
- 5) After ENTER is pressed, the timer momentarily displays Done!, then the Timeout Format menu option is shown again. Press NEXT CHOICE to change other rule options, or press SETUP to exit.

Changing Faults per Second (or other unit of time)

You can enter the faults per unit of time for First Round and for the Jump-Off Round. To change faults per unit of time, follow these steps:

- 1) Press **SETUP** to access timer setup features.
- 2) Press **NEXT CHOICE** until **Rule Options** is displayed, then press **ENTER**.
- 3) Press **NEXT CHOICE** until **Round 1 Faults** or **Jump Off Faults** is displayed (your choice), then press **ENTER**.
- 4) The current value of the “faults” portion of faults per unit of time is displayed. To keep the same value, press **ENTER**, or key-in a new value for

faults followed by **ENTER**. For example, press “1” then **ENTER** for whole faults. Key in “.25” then **ENTER** for ¼ faults.

- 5) After **ENTER** is pressed, the timer momentarily displays **Done!**, then **Sec(Σ)** is displayed to prompt for the unit of time. For example, key in “1” for faults per second, or key in “4” for faults per four seconds, then press **ENTER**.
- 6) After **ENTER** is pressed, the timer momentarily displays **Done!**, then the menu option you selected is shown again. Press **NEXT CHOICE** to change other rule options, or press **SETUP** to exit.

Miscellaneous Features

Using Three Sets of Electric Eyes

A third set of electric eyes provides the course designer with more flexibility in course layout. If three electric eyes are shown on the bottom right of the Status Display, the timer is ready for three eye operation. Otherwise, program Eye #3 into the timer as detailed in the “Learning a New ID Code” section of the “Wireless Electric Eyes” pages of this manual.

To remove the third set of eyes from the timer, follow the procedure for “Learning a New ID Code,” to the point where “Break Beam Now...” is displayed. However, instead of breaking the beam, press any key on the timer to abort the programming process. Eye #3 will be removed.

Power & Speed Classes

The Polaris timer includes a separate event specifically designed for Power & Speed classes. See the following page for details.

Start Timeout

If the timer automatically starts because the rider fails to cross the start line before the 45 second count down timer expires, the rider’s time is flagged with a “(T)” on the optional printer.

Table V (Optimum Time)

For Optimum Time classes, the large scoreboard can be automatically blanked while the competitor is on course, and then restored when the run is finished:

- 1) Press **SETUP** to access Setup options.
- 2) Press **PREV CHOICE** until **Scorebd Options** is displayed, then press **ENTER**.
- 3) Press **NEXT CHOICE** until **Run Time Off** is displayed, then press **ENTER**.

Normal operation is restored by choosing **Run Time On**, by picking another event, or cycling power.

Fault & Out Classes

For Fault & Out and similar classes, a warning horn can be set to sound at a specified time. Manually sounding the horn while the timer is running suppresses the warning horn for the current rider .

To set a warning horn, follow these steps:

- 1) Press **SETUP** to access Setup functions.
- 2) Press **NEXT CHOICE** until **Set Warn Horn 1** is displayed, then press **ENTER**.
- 3) To keep the time shown, press **ENTER**, or key in a new time followed by **ENTER**.

Preparation For Use

POWER & SPEED (1)

Power and speed classes require three sets of electric eyes. Eye #1 starts timing of the power phase. Eye #2 stops the power phase and starts the speed phase. Eye #3 stops the speed phase. Place the eyes in the appropriate location on course and follows these steps to complete preparation:

- 1) Attach each electric eye to a tripod. Place Transmitter/Receiver pairs facing each other to form start/stop lines between the eyes. *Extend tripod legs fully* to ensure the eyes are high enough to be broken by the horse's body (not its legs).
- 2) Turn the electric eyes ON. The power indicator lamp on each unit should glow steadily. If the indicator is blinking, the battery is low and should be replaced.
- 3) Align the electric eyes. The opposing electric eye should be directly in-line when sighting down either line on top of the electric eye (left to right

alignment), and when sighting down the crack on the side of the eye (up and down alignment).

- 4) Turn on the timer console in the announcer's booth. The power switch is located at the upper right corner of the timer.
- 5) The current event type is displayed on the timer. *If POWER PHASE is not displayed, select the Power & Speed event as follows:*
 - a) Press SETUP to access Setup options.
 - b) Press ENTER to pick a new event.
 - c) Press NEXT CHOICE until Power & Speed is displayed.
 - d) Press ENTER to select Power & Speed.
- 6) Walk through each electric eye beam to force the eyes to send a message to the timer console. This makes the timer console update its electric eye alignment indicator (see the next page).

Setting Course Times

A power phase course time and a speed phase course time should be specified.

Power Phase: The power phase starts when Eye #1 is broken and finishes when the rider breaks Eye #2, or exceeds twice the course time. If the rider completes the power phase prior to expiration of time allowed, then timing automatically begins for the speed phase. Otherwise, the horn sounds and timing stops upon completion of the power phase. If the power phase is not to be timed, enter a course time of zero for the power phase.

Speed Phase: The speed phase starts when Eye #2 is broken before expiration of the power phase course time. Upon expiration of the speed phase course time, accumulation of time faults commences. At twice the speed phase course time, the horn sounds and the timer is stopped. If time faults are not to be accumulated, enter a course time of zero for the speed phase.

To set the course times for the power and speed phases, follow these steps:

- 1) Press SETUP to access timer setup features.
- 2) Press NEXT CHOICE until the Pwr Phase Time option is displayed, then press ENTER.
- 3) To accept the course time shown, press ENTER, or key in a new time followed by the ENTER key. (To fix a mistake, press *and hold down* the CLEAR TIME key until the time is cleared).
- 4) After entering the power phase time, the option for entering the Spd Phase Time is displayed. Press ENTER to display the speed phase time.
- 5) To accept the speed phase course time shown, press ENTER, or enter a new course time followed by the ENTER key.
- 6) After entering the speed phase time, the option for modifying the time fault values for the power and speed phases is displayed. Press SETUP to exit the setup mode and return to normal timing.

Checking Eye Alignment

POWER & SPEED (2)

The bottom right corner of the Status display shows the alignment status of each electric eye. When an electric eye is aligned, its eye number is displayed. If not aligned, an “x” is displayed.

Alignment	Display Shows
Eyes aligned	Eye #1 Ξ Ξ
Eye #2 not aligned (or beam broken)	Eye #1 \times Ξ

Important! When setting up the electric eyes, always take time to align the eyes as outlined above – *even if the timer indicates the eyes are aligned*. This ensures a strong alignment instead of a possibly marginal alignment.

Timer Operation

- 1) The timer displays the most recently completed phase (POWER PHASE or SPEED PHASE) on the bottom display. It does not matter which phase is displayed before a rider starts – breaking Eye #1 will always start timing of the power phase.
- 2) Sound the horn and start a count down by pressing the COUNT DOWN button. Once started, the count down can be paused / resumed with successive presses of the COUNT DOWN button. Press CLEAR TIME to start a new count.
- 3) Make sure the electric eyes are enabled by pressing the EYES ON button before the rider is ready to cross the start line. When the rider crosses Eye #1, the timer begins timing from zero and the eyes are automatically turned back off.
- 4) If jumping faults occur, press the NO TIME button to prevent timing of the Speed Phase. Press NO TIME again to turn jumping faults back off.
- 5) As the rider nears the end of the power phase of the course, press the EYES ON button to re-enable the electric eyes. If the rider crosses Eye #2 before expiration of the power phase and with no jumping faults, timing of the speed phase begins automatically. The rider’s power phase time is shown on the timer’s Status display. If a scoreboard is connected, it shows the power phase time for several seconds before reverting to the running time of the speed phase.
- 6) As the rider comes to the end of the speed phase, press the EYES ON button to re-enable the electric eyes. When Eye #3 is crossed, the timer stops and the eyes are automatically turned back off. If the rider's time exceeds the time allowed, time faults are shown on the timer’s Status display. At twice the speed phase course time, the timer automatically stops and sounds the horn.

Useful Features

Dislodged Jump

If a rider dislodges a jump, sound the horn by pressing the HORN button and stop the clock by pressing the START/STOP button. Press RESTART (*not the START/STOP key*) to resume timing.

Previous Time Recall

Use the PREV and NEXT keys to scan back and forth through previous times, time faults and the associated phase are also shown.

Accidental Beam Break

If an electric eye accidentally stops the timer, the rider can still be accurately timed. Pressing the RESTART button resumes timing as if the timer had never been stopped. (**Note:** If the timer is manually

stopped using the START/STOP button, RESTART resumes timing from the time shown on the display)

Setup Options

Faults per second (or other unit of time) can be set for the power and speed phases using the Power Faults and Speed Faults setup options. See the “Advanced” page of the Show Jumping instructions for further information.

Duration of the starting count down timer can be changed using the Start Timeout setup option.

How long the scoreboard holds the power phase time can be changed using the Set Hold Time option of Scoreboard Options in the setup menu.

Preparation For Use (Using Electric Eyes)

CUTTING (1)

- 1) Attach each electric eye to a tripod. Place the eyes on opposite sides of the arena to form a start line between them. *Extend tripod legs fully* to ensure the electric eyes are high enough to be broken by the horse's body (not its legs).
- 2) Turn the electric eyes ON. The power indicator lamp on each unit should glow steadily. If the indicator is blinking, the battery is low and should be replaced.
- 3) Align the electric eyes. The electric eye on the opposite side of the arena should be directly in line when sighting down either line on top of the electric eye (left to right alignment), and when sighting down the crack on the side of the eye (up and down alignment).
- 4) After the timer console is turned on (see below), walk through the electric eye beam to force the eyes to send a message to the timer console. This makes the timer console update its electric eye alignment indicator (see below).

Preparation For Use (General)

- 1) With the timer console off, connect the timer console to whichever horn you are using (see the *Horn Operation* page).
- 2) Turn on the timer console in the announcer's booth. The power switch is located at the upper right corner of the timer.
- 3) The current event type (Barrel Racing, Cutting, etc.) is shown on the Status display on the timer console. *If CUTTING is not displayed, select the Cutting event as follows:*
 - a) Press SETUP to access Setup functions.
 - b) Press ENTER to select a new event.
 - c) Press NEXT CHOICE until Cutting is displayed.
 - d) Press ENTER to select the Cutting event.

Setting the Ride Time

The default time limit is 2:30. This can be changed as shown below. Once changed, the time limit is automatically saved in the timer until changed again by this same procedure.

- a) Press SETUP to access Setup functions.
- b) Press NEXT CHOICE once so Set Final Horn is displayed.
- c) Press ENTER to display the current horn setting.
- d) To keep the same time, press the ENTER button, or, key in a new time followed by the ENTER button. To correct a mistake while entering a time, *press and hold down* the CLEAR TIME key until the time is cleared to zero.

Checking Eye Alignment

The **bottom right corner** of the Status display shows the alignment status of the electric eyes. When the eyes are aligned, the eye number is displayed (“#1”). If not aligned, or if the beam is broken, “x” is shown.

Alignment	Display Shows
Eyes aligned	Eye #1
Not aligned (or beam broken)	Eye #x

Important! When setting up the electric eyes, always take time to align the eyes as outlined above – *even if the timer indicates the eyes are aligned*. This ensures a strong alignment instead of a possibly marginal alignment. (Note: Until the electric eye beam is broken for the first time, no alignment information is displayed.)

- 1) The timer automatically begins counting down from the time limit when the rider breaks the electric eye beam or the START/STOP button is pressed. (Note: The electric eyes only start the timer, they *will not stop* the timer).
- 2) When time expires, the horn is sounded and the timer automatically stops. At this time, a score can be entered (see *Entering a Score* below).

If the electric eyes are used, they are disabled whenever the timer stops. This allows arena preparation between riders without starting the timer. A flashing **OFF** message is displayed over the electric eye status to remind the operator that the eyes are disabled.

After the arena is cleared for the next rider, press the EYES ON button to re-enable the electric eyes.

Entering a Score

Press the SCORE/PENALTY button. Then, key in the score, followed by the ENTER key. Pressing the decimal point button moves the input cursor to the right of the decimal. However, zeros to the right of the decimal *do not* need to be entered.

After the score is entered, it is shown on the main time display, on the scoreboard, and on the printer (if connected). The score remains on the display and scoreboard until time starts for the next rider.

Correcting Mistakes

If a mistake is made while entering the score, press *and hold down* the CLEAR TIME button until the timer beeps and the score value is cleared.

If ENTER has already been pressed, simply start the score entry process over – the new score replaces the previous score.

Useful Features

Accidental Timer Stop

If the timer is accidentally stopped during a run, *the rider can still be accurately timed* by pressing the RESTART button. As long as RESTART is pressed before time expires, timing is resumed without any loss of time.

Previous Time/Score Recall

Use the PREV and NEXT keys to scan back and forth through previous times and scores. The previous time display is removed after ten seconds, or by

pressing any other key. You may view a previous score even while the timer is running.

Skipping a Rider / No Score

Pressing the NO TIME button prints "-- No Score --" on the optional printer. This ensures a line is present on the printer for each contestant registered to ride. If a score is not entered for a rider, the printer *automatically* prints "--No Score--" for the rider when the timer starts for the next contestant.

Preparation For Use (Using Electric Eyes)

TEAM PENNING (1)

- 1) Attach each electric eye to a tripod. Place the eyes on opposite sides of the arena to form a start line between them. *Extend tripod legs fully* to ensure the electric eyes are high enough to be broken by the horse's body (not its legs).
- 2) Turn the electric eyes ON. The power indicator lamp on each unit should glow steadily. If the indicator is blinking, the battery is low and should be replaced.
- 3) Align the electric eyes. The electric eye on the opposite side of the arena should be directly in-line when sighting down either line on top of the electric eye (left to right alignment), and when sighting down the crack on the side of the eye (up and down alignment).
- 4) After the timer console is turned on (see below), walk through the electric eye beam to force the eyes to send a message to the timer console. This makes the timer console update its electric eye alignment indicator (see below).

Preparation For Use (General)

- 1) With the timer console off, connect the timer console to whichever horn you are using (see the *Horn Operation* instructions page).
- 2) Turn on the timer console in the announcer's booth. The power switch is located at the upper right corner of the timer.
- 3) The current event type (Barrel Racing, Team Penning, etc.) is shown on the Status Display on the timer console. *If TEAM PEN is not displayed, select Team Penning as follows:*
 - a) Press SETUP to access setup functions.
 - b) Press ENTER to pick a new event.
 - c) Press NEXT CHOICE until Team Penning is displayed.
 - d) Press ENTER to select Team Penning.

Setting Horn Times

Default horns are at 30 and 60 seconds (warning horn and final horn, respectively). These can be changed as shown below. Once changed, the new horn times are automatically saved in the timer until changed again by this same procedure.

- a) Press SETUP to access setup functions.
- b) Press NEXT CHOICE until Set Final Horn or Set Warn Horn (your choice) is displayed.
- c) Press ENTER to display the current horn setting.
- d) To keep the same time, press the ENTER button, or, key in a new time followed by the ENTER button. To correct a mistake while entering a time, *press and hold down* the CLEAR TIME key until the time is cleared to zero.

Checking Eye Alignment

The **bottom right corner** of the Status display shows the alignment status of the electric eyes. When the eyes are aligned, the eye number is displayed (“#1”). If not aligned, or if the beam is broken, “x” is shown.

Alignment	Display Shows
Eyes aligned	Eye #1
Not aligned (or beam broken)	Eye #x

Important! When setting up the electric eyes, always take time to align the eyes as outlined above – *even if the timer indicates the eyes are aligned*. This ensures a strong alignment instead of a possibly marginal alignment. (Note: *Until the beam is broken for the first time, no alignment information is displayed.*)

Timer Operation

- 1) The timer automatically begins timing from zero when the lead rider breaks the electric eye beam or the START/STOP button is pressed.
- 2) When the warning horn time is reached, the horn sounds and the timer continues to run.
- 3) Press the START/STOP button to stop the timer when the cattle are successfully penned.
- 4) When time expires, the horn sounds and the timer stops at the final time + 0.01 seconds.

TEAM PENNING (2)

If the electric eyes are used, they are disabled whenever the timer stops. This allows arena preparation between teams without starting the timer. A flashing Off message is displayed over the electric eye status to remind the operator that the eyes are disabled.

After the arena is cleared for the next team, press the EYES ON button to re-enable the electric eyes.

(Note: The electric eyes only start the timer, they *will not stop* the timer).

Cattle Number Selection

By default, the timer automatically generates random cattle numbers. The Status Display shows the cattle number assigned to the current team and the cattle number to be assigned to the next team.

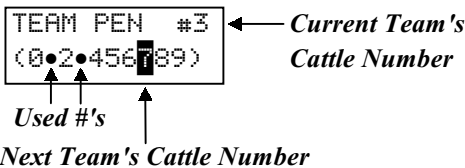

Each time the timer is started, the "next" cattle number is assigned to the current team, and a new cattle number is selected for the next team.

If a scoreboard is connected, the team's cattle number is automatically displayed when the timer starts. The cattle number remains on the scoreboard for 15 seconds, after which, the running time is displayed.

Forcing a New Cattle Number

If the cattle number for the next team is unacceptable, force a new cattle number selection:

- 1) Press the CATTLE NUM button.
- 2) Press "0" (as prompted) to reject the current number and force the timer to pick a new number.

Forcing a New Set of Cattle Numbers

- 1) Press the CATTLE NUM button.
- 2) Press "1" (as prompted) to force selection of a new set of numbers and a new cattle number.

Choosing a Reduced Set of Cattle Numbers

- 1) Press the SETUP button.
- 2) Press NEXT CHOICE until Max Cattle Num is displayed and then press ENTER.
- 3) Press the highest cattle number to be used.

Cattle Number Settings

The Polaris timer provides several options for controlling the generation of cattle numbers:

When to Display the Cattle Number

- When timer starts (Display w/Start) or...
- When the number is entered or accepted via the CATTLE NUM key (Display w/Input).

How the Cattle Number is Obtained

- Timer automatically generates the cattle number (Auto Cattle#) or...
- Cattle number manually entered by pressing the CATTLE NUM button (Manual Cattle#).

How Long the Cattle# Stays on Scoreboard

(Display for 5, 10, 15, or 30 seconds).

To change one of these options:

- 1) Press SETUP to access setup features.
- 2) Press NEXT CHOICE until Setup Cattle# is displayed.
- 3) Press ENTER to display the cattle number menu.
- 4) Press NEXT CHOICE until the desired option (the items shown in parenthesis) is displayed.
- 5) Press ENTER to activate the displayed choice.

Overview

RANCH SORTING (1)

Ranch Sorting is run under the Team Penning event on the timer console. Ranch Sorting shares timer features with Team Penning such as the warning horn, final horn, cattle number selection, etc.

In Ranch Sorting, a wireless handswitch is used with the timer to record the time each cow is penned. This eliminates the need for a separate stopwatch to

generate these split times. Each time the handswitch is pressed, the running time is captured and shown on the timer's status display. If a scoreboard is in use, the cow's time is shown momentarily on the scoreboard to allow the audience to see the time at which the cow was penned. After the last cow is penned, the timer automatically stops.

Timer Operation

Ranch Sorting is run under the Team Penning event on the timer console. Follow the "Preparation For Use (General)" section of the Team Penning instructions to prepare the timer for operation.

Follow these steps to time a team:

- 1) Start the timer by pressing the wireless handswitch or by pressing the START/STOP button on the timer console. (The electric eyes will also start the timer, but eyes are not typically used.)
- 2) Press the handswitch as each cow is penned. The time at which the handswitch is pressed and the count of cows penned is shown on the timer's status display. If a scoreboard is in use, the pen time is frozen momentarily on the scoreboard.
- 3) When the warning horn time is reached, the horn sounds and the timer continues to run.
- 4) If all cows are penned before the expiration of time, the timer automatically stops. The timer can also be stopped by pressing the START/STOP button on the timer console.
- 5) If time expires, the horn sounds and the timer stops at the final time + 0.01 (e.g., 60.01). This allows a pen at exactly 60.00 seconds.
- 6) The judge can continue pressing the handswitch until he hears the horn – the timer automatically ignores any presses after the time limit. Once the horn sounds, the handswitch is ignored for about three seconds, after which the next press of the handswitch starts the timer for the next team.

Advanced Settings

Cattle Number Features

See the Team Penning section to read about several cattle number features that can be selected.

Automatic Stop after Last Cow

The timer can be set to automatically stop after the last cow is penned (default), or continue running. To change this setting, press SETUP, then press NEXT CHOICE several times until Auto Stop or No Auto Stop (your choice) is displayed, then press ENTER.

Scoreboard Hold Time

To change the duration a pen time remains frozen on the scoreboard, press SETUP, then press NEXT CHOICE several times until Split Times is dis-

played, then press ENTER. Press NEXT CHOICE a few more times until the desired hold time is displayed, then press ENTER.

Handswitch Usage

To use the handswitch for Team Penning (i.e., to just start and stop the timer), you must change the "Handswitch Usage" menu option. Press SETUP, then press NEXT CHOICE several times until Handsw Usage is displayed, then press ENTER. Press NEXT CHOICE to scan through the available usage options, and press ENTER when the desired option is shown. Note: Choose the Ranch Sorting option to restore operation as described above.

Preparation For Use

SPRINT/GENERAL (1)

The Sprint/General event can be used to time a wide variety of non-standard events. The most common is to time from Point “A” to Point “B”. These instructions follow. Look under “Advanced Features” on the next page and on Sprint/General page 3 for more features.

- 1) Attach each electric eye to a tripod. Place Transmitter/Receiver pairs facing each other to form start/stop lines between the eyes. Adjust the tripod height to ensure the beam is broken by the body of the horse or vehicle.
- 2) Turn the electric eyes ON. The power indicator lamp on each unit should glow steadily. If the indicator is blinking, the battery is low and should be replaced.
- 3) Align the electric eyes. The opposing electric eye should be directly in-line when sighting down either line on top of the electric eye (left to right alignment), and when sighting down the crack on the side of the eye (up and down alignment).
- 4) Turn on the timer console in the announcer's booth. The power switch is located at the upper right corner of the timer.
- 5) Walk through each electric eye beam to force the eyes to send a message to the timer console. This makes the timer console update its electric eye alignment indicators (see below).

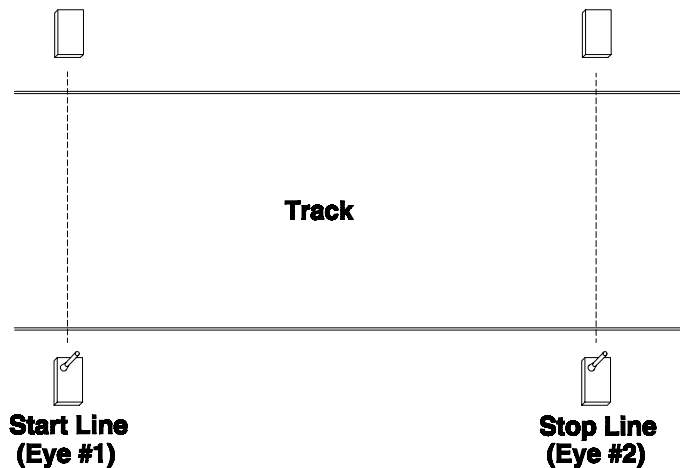

Checking Eye Alignment

The **bottom right corner** of the Status display shows the alignment status of the electric eyes. When the eyes are aligned, its number is displayed (1 or 2). If not aligned, or if the beam is broken, “x” is shown.

Alignment	Display Shows
Eyes aligned	Eye #1 Ξ
Eye #2 not aligned (or beam broken)	Eye #1 \times

Important! When setting up the electric eyes, always take time to align the eyes as outlined above – *even if the timer indicates the eyes are aligned*. This ensures a strong alignment instead of a possibly marginal alignment.

- | | |
|--|--|
| <p>1) When the electric eye beam across the start line is broken, the timer automatically begins timing from zero – there is no need to reset the timer.</p> | <p>2) When the electric eye beam across the finish line is broken, the timer stops timing and shows the final time. The timer is ready for the next run!</p> |
|--|--|

Useful Features

Manual Start/Stop

The START/STOP button starts and stops the timer just as if the electric eye beam had been broken.

Accidental Beam Break

If the timer stops accidentally stops during the middle of a run, *the rider can still be accurately timed* (the Polaris timer continues timing even while the timer is stopped!). Pressing the RESTART button resumes timing as if the timer had never been stopped. As long as RESTART is pressed before the ride is completed, the time is not lost. (Note: The Polaris timer console beeps whenever the beam is broken to alert you if the timer happens to stop during the middle of a run.)

Locking Out The Electric Eyes

Some events require the rider to pass through the beams several times during a run. For these events, the eyes can be disabled during the run, then re-enabled before the rider completes the run. To disable the electric eyes, press the EYES OFF button. "Off" is flashed over the electric eye alignment display while the eyes are off. To re-enable the electric eyes, press the EYES ON button.

Previous Time Recall

Use the PREV and NEXT keys to scan back and forth through previous times. The previous time display is removed after about ten seconds, or by pressing any other key. You may view a previous time even while the timer is running.

Advanced Features

In addition to starting the timer with Eye #1 and stopping the timer with Eye #2, the timer provides several other electric eye combinations as shown to the right.

To select a different electric eye combination:

- 1) Press SETUP to access Setup options.
- 2) Press NEXT CHOICE once so Set Eye Usage is displayed, then press ENTER.
- 3) Press NEXT CHOICE to scan through the available eye combinations as shown to the right. Press ENTER when the desired eye combination is displayed.

Note: An asterisk (*) is displayed next to the currently active eye combination.

Timer Display	Timer Action
Start #1, Stop #2	Start with Eye #1, Stop with Eye #2.
Start #2, Stop #1	Start with Eye #2, Stop with Eye #1.
Strt1/2 Stop2/1	Start with either eye, then stop with the opposite eye.
Any Start/Stop	Start with either eye, stop with either eye.
Breakout Timer	Time difference between steer and rider for roping.
Winning Lane	Start with either eye, then stop with the opposite eye, indicate which eye started the timer (winning lane).

Breakout Timer

SPRINT/GENERAL (3)

The *Breakout Timer* is part of the Sprint/General event. It allows you to time the interval from when the steer crosses the score-line to when the rider exits the box (or vice-versa). This is a great practice tool for getting the best jump possible on the steer.

If the steer leads the rider, it is a clean start. If the rider leads the steer, a breakout has occurred. In the case of a breakout, the horn sounds (if attached), the bottom display shows “Breakout” and the scoreboard,

if used, shows a negative time instead of a positive time.

To use the *Breakout Timer* function, select the *Breakout Timer* option as detailed under “Advanced Features” on the previous page. Once you have selected the Breakout Timer option, it will already be selected whenever you choose the Sprint/General event in the future.

Split Times

In addition to the various combinations of Eye #1 and Eye #2 for starting and stopping the timer detailed on the previous page, the timer can also work with up to two more eyes for providing split times. As split times occur, they are displayed on the bottom display while the main time display continues to run. If a scoreboard is connected, the split time is displayed for an interval you can specify before the display returns to showing the running time.

The split-time eyes are designated Eye #3 and Eye #4. Options for controlling split time functions are in the Split Times menu. To access the Split Times menu, follow these steps:

- 1) Press SETUP to access Setup options.
- 2) Press PREV CHOICE until Split Times is displayed, then press ENTER.

You can then scroll through the Split Times options by pressing the NEXT CHOICE key:

Timer Display	Function
Set Eye #3 ID	Program Eye #3 into timer.
Set Eye #4 ID	Program Eye #4 into timer.
Print Times ON/OFF	Controls whether split times are printed on the printer.
Save Times ON/OFF	Controls whether split times are saved in memory.
Hold for 1/3/5/10s	Choose the amount of time a split time is displayed on the scoreboard.

Preparation For Use

LAP TIMING (1)

- 1) Attach each electric eye to a quick-mount. Place the eyes on opposite sides of the track to form a start/stop line between them.
- 2) Turn the electric eyes ON. The power indicator lamp on each unit should glow steadily. If the lamp blinks, the low battery should be replaced.
- 3) Align the electric eyes. The electric eye on the opposite side of the arena should be directly in-line when sighting down either line on top of the electric eye (left to right alignment), and when sighting down the crack on the side of the eye (up and down alignment).
- 4) Turn on the timer console in the announcer's booth. The power switch is located at the upper right corner of the timer.
- 5) The current event is shown on the Status display on the timer console. *If LAP TIMING is not displayed, select the Lap Timing event as follows:*
 - a) Press SETUP to access setup functions.
 - b) Press ENTER to select a new event.
 - c) Press NEXT CHOICE until Lap Timing is displayed.
 - d) Press ENTER to select Lap Timing
- 6) Walk through the electric eye beam to force the eyes to send a message to the timer console. This makes the timer console update its electric eye alignment indicator (see the next page).

Entering a Track Length

The timer can compute lap speed as well as lap time. To compute speed, a track length must be entered. Once the track length is entered, it is permanently saved in the timer. You do not need to re-enter the track length each time you use the timer, unless a different track length is desired.

To set the track length follow these steps:

- 1) With the timer stopped, press the SETUP button to access the timer's setup features.
- 2) Press NEXT CHOICE until the display shows Press ENTER for Track Length.
- 3) Press ENTER to display the current track length.
- 4) If the displayed track length is OK, press the ENTER button to keep the same value. Otherwise, key in a new track length followed by the ENTER key. (To correct a mistake, press and *hold down* the CLEAR TIME button until the track length value is cleared to zero).

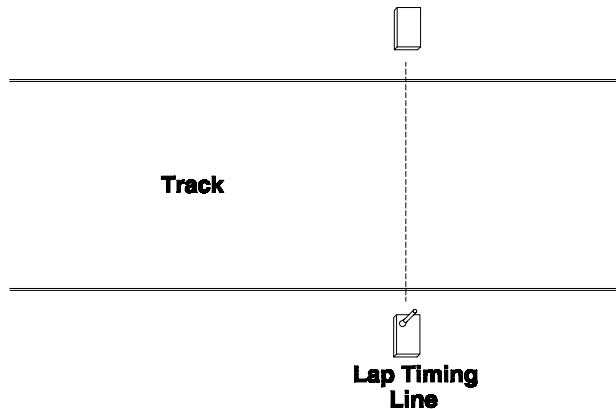

Typical Track Setup

Checking Eye Alignment

LAP TIMING (2)

The **bottom right corner** of the Status display shows the alignment status of the electric eyes. When the eyes are aligned, the eye number is displayed (“#1”). If not aligned, or if the beam is broken, “x” is shown.

Alignment	Display Shows
Eyes aligned	Eye #1
Not aligned (or beam broken)	Eye #x

Important! When setting up the electric eyes, always take time to align the eyes as outlined above – *even if the timer indicates the eyes are aligned*. This ensures a strong alignment instead of a possibly marginal alignment.

Timer Operation

- 1) Make sure the timer is stopped before the driver starts his laps (press the START/STOP button to stop the timer, if needed).
- 2) When the car breaks the beam at the start of the first lap, the timer automatically begins timing from zero.
- 3) As the car breaks the beam after each lap, the bottom display shows the lap number, lap time, and lap speed (if a track length has been entered). Meanwhile, the main time display shows the running time of the new lap.
- 4) After the driver has completed all laps, press the START/STOP button to stop timing of the current driver. The timer is now ready for the next car.

By the way...

If the optional printer is connected, the lap time, lap number and lap speed are printed after each lap.

If an optional scoreboard is connected, it shows the running time as the lap is timed. When a lap is completed, the lap time remains on the display for about five seconds, after which, it returns to showing the running time of the new lap. (The amount of time the previous lap remains displayed can be changed. Contact FarmTek for assistance).

To avoid false triggers, the beam is ignored for about two seconds after it is broken to allow dust and debris to settle.

Useful Features

Accidental Manual Stop

If the timer is inadvertently stopped by pressing the START/STOP button, *the lap can still be accurately timed* by pressing the RESTART button. This resumes timing as if the timer had never been stopped. As long as RESTART is pressed before the lap is completed, the time is not lost.

Locking Out The Electric Eyes

If the beam will be broken during a lap by other vehicles, the timer can be forced to temporarily ignore the electric eyes. To disable the electric eyes, press the EYES OFF button. **Off** is flashed on the bottom display while the eyes are off. To re-enable the electric eyes, press the EYES ON button.

Note: If other cars or personnel on the track during lap timing is typical, then the timer can be set to *automatically* turn the eyes off after any beam break. This way, the eyes remain disabled the majority of the time – the timer operator re-enables the eyes by pressing the EYES ON button only when the desired car comes near the beam. Contact FarmTek for more information.

Previous Time Recall

Use the PREV and NEXT keys to scan back and forth through previous times. The previous time display is removed after about ten seconds, or by pressing any other key. You may view a previous time even while the timer is running.

FCC and Industry Canada Information

This equipment has been tested and found to comply with the limits for a Class B digital device, pursuant to Part 15 of the FCC Rules. These limits are designed to provide reasonable protection against harmful interference when the equipment is operated in a residential installation. This equipment generates, uses, and can radiate radio frequency energy and, if not installed and used in accordance with the instruction manual, may cause harmful interference to radio communications. However, there is no guarantee that interference will not occur in a particular installation.

If this equipment does cause harmful interference to radio or television reception, the user is encouraged to try to correct the interference by one or more of the following measures: (1) Reorient or relocate the receiving antenna. (2) Increase the separation between the equipment and the receiver. (3) Consult the dealer or radio/TV technician for help.

CAUTION: Changes made or modifications not expressly approved by the party responsible for FCC compliance of this equipment could void the user's authority to operate the equipment.

Industry Canada

Under Industry Canada regulations, this radio transmitter may only operate using an antenna of a type and maximum (or lesser) gain approved for the transmitter by Industry Canada. To reduce potential radio interference to other users, the antenna type and its gain should be so chosen that the equivalent isotropically radiated power (e.i.r.p.) is not more than that necessary for successful communications.

This radio transmitter (IC: 3845A-MI043) has been approved by Industry Canada to operate with the antenna types listed below with the maximum permissible gain and required antenna impedance for each antenna type indicated. Antenna types not included in this list, having a gain greater than the maximum gain indicated for that type, are strictly prohibited for use with this device.

¼ wave whip, max gain 2 dBi, 50 ohm

This device complies with Industry Canada license-exempt RSS standard(s). Operation is subject to the following two conditions: (1) this device may not cause interference, and (2) this device must accept any interference, including interference that may cause undesired operation of the device.

d'Industrie Canada

Conformément à la réglementation d'Industrie Canada, le présent émetteur radio peut fonctionner avec une antenne d'un type et d'un gain maximal (ou inférieur) approuvé pour l'émetteur par Industrie Canada. Dans le but de réduire les risques de brouillage radioélectrique à l'intention des autres utilisateurs, il faut choisir le type d'antenne et son gain de sorte que la puissance isotrope rayonnée équivalente (p.i.r.e.) ne dépasse pas l'intensité nécessaire à l'établissement d'une communication satisfaisante.

Le présent émetteur radio (IC: 3845A-MI043) de modèle s'il fait partie du matériel de catégorie I) a été approuvé par Industrie Canada pour fonctionner avec les types d'antenne énumérés ci-dessous et ayant un gain admissible maximal et l'impédance requise pour chaque type d'antenne. Les types d'antenne non inclus dans cette liste, ou dont le gain est supérieur au gain maximal indiqué, sont strictement interdits pour l'exploitation de l'émetteur.

¼ whip d'onde, le gain max 2 dBi, 50 ohm

Le présent appareil est conforme aux CNR d'Industrie Canada applicables aux appareils radio exempts de licence. L'exploitation est autorisée aux deux conditions suivantes : (1) l'appareil ne doit pas produire de brouillage, et (2) l'utilisateur de l'appareil doit accepter tout brouillage radioélectrique subi, même si le brouillage est susceptible d'en compromettre le fonctionnement.

FarmTek, Inc.
1000-D Hwy 78 North
Wylie, TX 75098

(800) 755-6529
(972) 429-0947
(972) 429-1379 (fax)

On the web at <http://farmtek.net>
E-Mail: info@farmtek.net